



SHEET METAL CONNECTORS, INC.

www.smcduct.com

MINNEAPOLIS, MN
5850 Main Street N.E.
Minneapolis, Minnesota 55432
LOCALLY CALL: 763-572-0000
TOLL FREE: 1-800-328-1966
FAX: 763-572-1100

ROCKFORD, IL
5601 Sandy Hollow Road
Rockford, Illinois 61109
LOCALLY CALL: 815-874-4600
TOLL FREE: 1-866-504-4600
FAX: 815-874-9979



Full Saddles

SMC spiral fittings are manufactured with an elbow lock seam, lap seam (i.e. stitch weld, riveted, tack weld or solid weld), standing seam or butt weld seam. These may be with or without duct sealant.

Full Saddles are manufactured with a 2.5" flange attached for ease of installation.

Round end can be manufactured with:

- Complete Seal Spiral Pipe System - 6" to 24" Diameter (even sizes)
- E-Z Flange Jr. with Barrel Clamp - 6" to 24" Diameter
- E-Z Flange with Barrel Clamp - 26" to 96" Diameter
- Standard Spiral End
- Companion Angle Ring

90° Full Saddle

Dimensions to be listed as follows: A on B

All Fittings are 1.75" from Bead to End of Fitting.

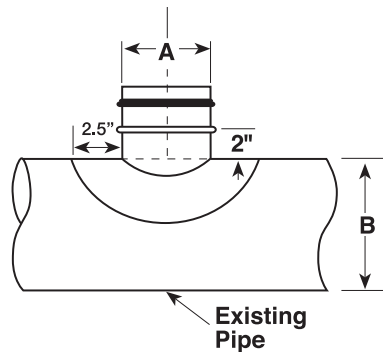

45° Full Saddle

Dimensions to be listed as follows: A on B

All Fittings are 1.75" from Bead to End of Fitting.

